

Instant Replay-The Physics of Bodies in Motion

Debra Blake Semmler

Introduction

One of my favorite shows on television is *Mythbusters* where scientific experimentation is used to debunk or support urban myths. One of the best parts of *Mythbusters* is the use of high speed video to see the unseen. Being able to see what your eye can not detect is fascinating, so much so that Discovery Channel has created a new show called *Time Warp* where they use the newest high tech photography to see invisible motion. What I am hoping to accomplish in this curriculum unit is to allow students to use high speed video to see the unseen motion of sports related action and analyze the physics of bodies in motion. The use of the high speed camera makes it possible to see the ball compress when it bounces. It can make the water look like it is still in the shape of the water balloon after the balloon is broken. When the high speed camera is turned on to people moving in the act of jumping, landing, hitting, throwing and catching many measurements of distance and time can now be made by using the camera frame speed and a frame of reference for measurement of distance. From these measurements students can calculate the speed, acceleration and forces acting on a body in motion. I will include in this curriculum unit instruction and discussion about the biomechanics of the human body and how muscles apply force to the body. I will also teach students how to determine the coefficient of restitution (COR) of objects when colliding.

School/Classroom Environment

I teach at an urban, partial magnet high school of about 1800 student approximately 600 students are part of the International Baccalaureate (IB) magnet. The school is comprised of approximately 49 % Africans American, 28 % white, 15% Hispanics and 6 % Asian. More than 50% of the student population is on free and reduced lunch. I teach introductory algebra-based physics to tenth, eleventh and twelfth grade students on a semester block program. The tenth grade students are part of the International Baccalaureate (IB) magnet program at my school. I also teach advanced placement (AP) algebra and calculus based physics courses and the upper level IB Physics courses. The IB Physics 2 and 3 are taught on an A-day/B-day schedule over two years with standard level (SL) and higher level (HL) students mixed within the same classroom. I will use most of the curriculum unit materials in the upper-level IB physics classes, as a plan-your-own lab where students will develop their own experiments involving motion and sports.

Rational

The analysis of the high speed video of bodies in motion is very similar to the analysis of many problems physics students encounter in any classroom and they will just be adding their own data from the video to analyze the motions. The unit will be used with second and third year students so the students will have already completed the study of kinematics including momentum and energy and should understand how to analyze the motion of a rigid body, such as a ball, neglecting air resistance. For students to be able to analyze the physics of slow motion video clips of them performing an action they must first understand the differences in motion of a human and the motion of an object. The human body has multiple parts that can move relative to each other using muscular force. So how does this change the force, energy, position, velocity and acceleration of a moving object? This difference between human and rigid objects is what I need to convey to the students before they do their analysis.

To form an analysis of any motion we would make measurement of the changes in motion from the center of mass (or gravity) of the object. The center of mass of an object is the point around which a bodies mass are equally balanced in all directions. In my introductory physics class the center of mass may be simply discussed but the objects being studied are always uniformed and rigid so the center of mass is in the center of the object or if not we assume so. In my more advance classes (AP or IB physics) I teach them how to calculate the center of mass of an irregular shaped object and will demonstrate the concept of center of gravity with a balancing bird, but the use of a changing center of mass when moving is never discussed. (The balancing bird is a plastic bird with weights in its wings so that the center of mass is directly over the beak so it can balance in a stable equilibrium on the end of your finger.) For this curriculum unit I must include instruction on the center of mass of people.

So where is the center of mass of people? First, assuming you are symmetrical the center of mass would be on the mid-line in the vertical plane and approximately 55% of your height in the horizontal plane. For example, if you are 180 cm in height (5'11") then when standing with your hand to your sides your center of mass will be 100 cm off of the floor. If you are 160 cm (5'3") your center of mass will be 88 cm off of the floor. However, your center of mass can change if you move your arms above your head more of your mass is farther from the floor and therefore your center of mass is farther off the floor. The change in the center of mass is the result of a net force acting on the body from the muscles contracting and pushing against the floor.¹ The contraction of muscles that causes motion of individual parts of the body can affect the motion of an object.

A Simplified Model of Muscle Motion

To model the effect of muscles on the body we will assume the motion and forces of muscles acting on two masses or body segments that are attached by a joint. The joint is attached to the two body segments by muscle tissue which acts like a spring. A simplified model can be two mass attached by an ideal spring as shown in Figure 1a. The two mass are not identical and lying on a frictionless surface one mass is twice the mass ($2m$) of the other. The ideal spring which is mass-less compared to the attached masses has a linear relationship between force and length. The center of mass of the system will be located one-third of the distance from the $2m$ mass. If the masses are pushed together as in the contraction of the muscle fibers the mass will undergo simple harmonic motion. Analysis of the motion using the conservation of momentum and energy will result in the velocity of the heavy block is one half of the velocity of the light block and the maximum change in displacement of the larger block is twice the displacement of the smaller block. The result of this analysis is that the center of mass will not move relative to either block or no change in the center of mass. The net force of the system is zero. An example, of this is treading water in a pool and when you lift your arms over your head the relative location of your center of mass has not changed because there is no net force acting on your body parts.

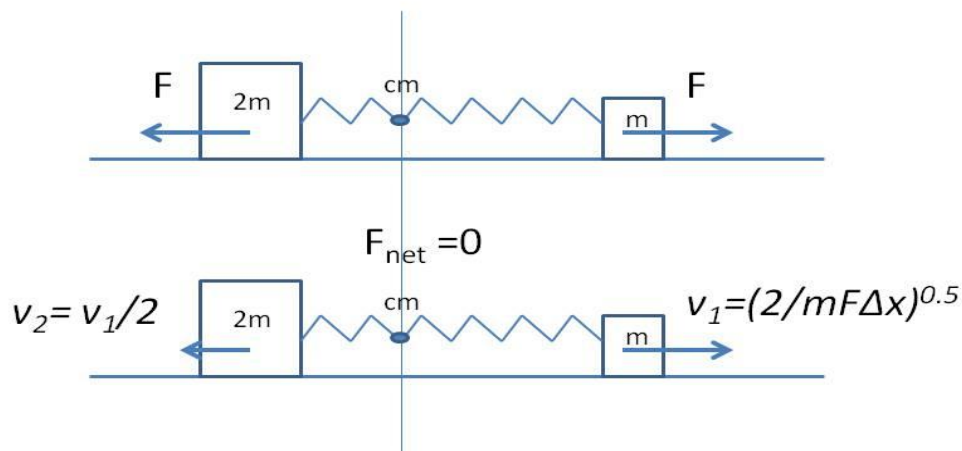

Figure 1a internal muscle force leaves the center of mass stationary

Now, if the heavy block is placed against a wall which provides an external force (this could be the floor or horizontal friction from the floor) as shown in Figure 1b. The wall provides a net external force. Using the impulse-momentum relationship and the

conservation of energy the resulting analysis is the center of mass of the system is changed. What this illustrates is that a body can gain momentum and energy only if part of the body is acted upon by a net external force. This means that to change the location of our center of mass or move we must have something to push against, if we do not our body parts can change their orientation but our center of mass will not change. The result of this analysis is that humans in freefall (airborne) can move their arms and legs relative to each other by muscular contraction but this will not change the path of the center of mass of the body. So analysis of a moving human is exactly the same as the rigid body as long as there is not external force acting on the body and the analysis of free fall or projectile motion will not change (still neglecting air resistance.) This is important for the students to understand because to change the location of your center of mass, jump, run, walk, or any other motion there must be a net force acting on the body. Seems simple but is often not discussed or considered because the analysis of this net force can be difficult.²

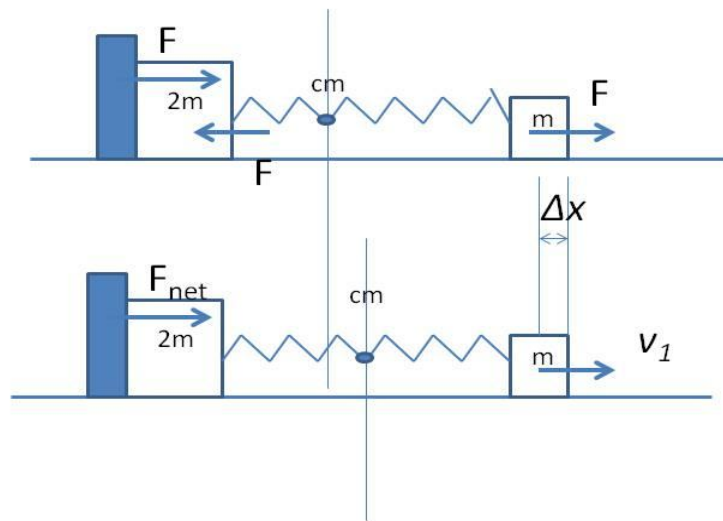

Figure 1b internal muscle action while the presence of an external reaction will result in moving the center of mass

The Biomechanics of Muscles

Muscles are like little engines. They use energy to produce a force and generate heat in the process. In humans, muscle tissue is constructed from many small fibers connected in

parallel that generally run the whole length of the muscle from the tendon at one end to the tendon at the end. The force produced by the muscle is controlled by the number of fibers that are activated and the type of fiber activated. The mechanical process of the complex electrochemical activity between the nervous system and the actuation of a muscle fiber is not fully understood but the output of the force from a group of muscle fibers is well understood.³ This relationship is shown in a Hill type model of muscle force. A.V. Hill, in 1938, published a paper on the muscle contraction and in his simplified version the force increases when the number of active nerve fiber increase.⁴ The active forces are at a maximum at an intermediate length and decrease as the muscles are shorter or longer. The general shape of the force length graph is the same but the length for maximum force depends on the body muscle used. For example the bicep muscle optimum length is different than the quadriceps. There is a passive restraint force to the muscle stretching; it begins to resist at some initial length and further stretches, resulting in increasing resistance or force. This is also different for different joint angles.⁵

The Hill model consist of three parts the Series Elastic Component(SEC) and is assumed to be a spring with its' length and stiffness determined by the muscle force as shown in figure 2a which follows a Hooke's model of elastic force. The second element is the Contractile Component (CC) and the force is related to the speed, v , of the shortening of the muscle. The series elastic component and the contractile element work in series together. The third part of the Hill model is the Parallel Elastic Component (PEC) which is the elastic properties of the unstimulated part of the muscle.⁶

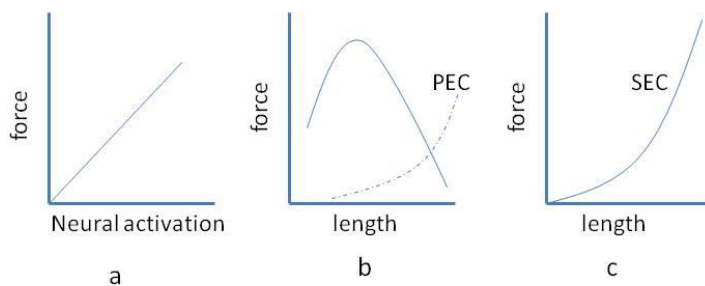
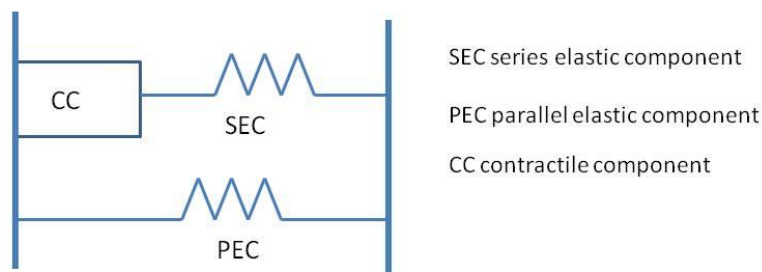

Figure 2 Hill model of muscle for force and length

Figure 2a shows the force increases when the number of active nerve fibers increases in the Hill-type model. In Figure 2b, the force of the muscle group is at a maximum at some intermediate length. The broken line indicates the passive elasticity in the muscle due to connective tissue and acts parallel to the series elastic component. When stretching a muscle at some length the parallel elastic component (PEC) begins to increase as a resistive force which decreases the total force of the muscle group. When performing stretching exercises we all feel this resistive force to the stretching. Figure 2c shows the combination of the series elastic component (SEC) and the contractile component (CC) force-length behavior which becomes stiffer as the contractile component (CC) of the muscle becomes greater.

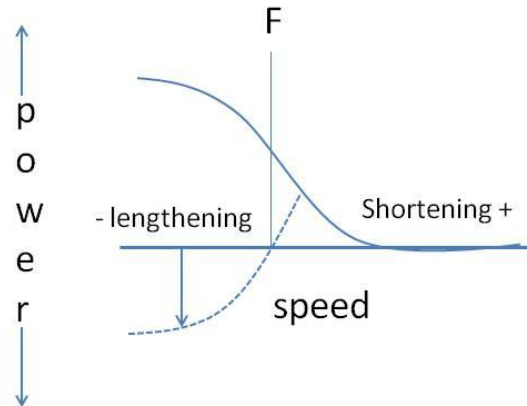

Figure 3 Hill model of Force and lengthening

Figure 3 shows the important relationship between power and speed. As the muscle shortens more quickly the maximum force decreases. Alternatively the faster it lengthens the more force it can produce. The dashed line indicates the negative power produce is greater than the positive power at any given speed of lengthening or shortening. If the lengthening speed becomes too great the muscle will rupture.⁷

Muscles are extremely strong. The force produced by a given amount of muscle is about 25N per square centimeter of cross section. This means that a muscle the diameter of a pencil can support a weight of about 800g or 1.8 pounds. Your calf muscle has a cross section area of about 80 cm² and can sustain a force of around 4000N or 880

pounds. This is why we can do toe raises on one foot. Muscles do seem to have a sort of memory but only in very short term. That means a stimulated muscle will produce more force following a stretch or motion than if it had not been stretched. This effect is useful but only short lived, there is no use in stretching an active muscle and expecting to have better performance a second later. Most athletes know that to move prior to the actual motion, action of muscle prior increases the force of the muscle.⁸

There are two types of muscle fibers or force producers. Red or slow fibers develop force slowly and can sustain repetitive motion by using oxygen delivered by the blood system over a period of time. A white or fast fiber that can act rapidly but cannot do many repetitions because of the type of chemical energy they use is not fed by the blood system, they are used for high acceleration situations.

There are three types of muscle motion. The first is “concentric” (toward the center) contraction in which the muscle force pulls the two ends of the muscle together. The force and change in length are in the same direction. We use this type of muscle force when we stand up or lift an object.

The next type in lengthening the muscular force is tending to pull the muscle ends together while the muscle is lengthening when an external force such as gravity is present. This is an “eccentric” (away from the center) contraction. When we sit or put down an object slowly in a gravitational field we use “eccentric” muscular contraction. This type of muscle contraction is more energy efficient. If we fall or drop the object there is no muscular contraction. This explains why it is more tiring to walk up hill (concentric contraction) than down hill (eccentric contraction).

The third type is “isometric” contractions. These occur without a change in length of the muscle therefore no external work is done, $F\Delta x = 0$, but internal micro-movements of the muscle are occurring and this requires energy and liberates heat.⁹

Demonstration of External Force on Human Body

In the classroom, I will describe and use the Hill model and graphs to explain the various muscle motions but what we are interested in is the amount of external force applied to the body. Consider standing on a bathroom scale, in this case the scale is reading the reaction force from your weight or the force due to gravity. Now bend your knees into a crouching position while standing on the bathroom scale. Initially, when at rest (in the crouching position) the bathroom scale will read your weight but as you move (by contracting your leg muscles) the scale reading will increase then decrease and stop at your weight when standing upright. The change in your center of mass is a result of the net force and acceleration created by your muscles applying a force to the floor (see figure 4.) I will use this demonstration to demonstrate the amount of reaction force from the floor which is from the muscles contracting. We can also use the scale to measure the muscle force from lifting the arms over the head (one or both).¹⁰

Figure 4 the change in scale reading with the change in center of mass by using your leg muscles.

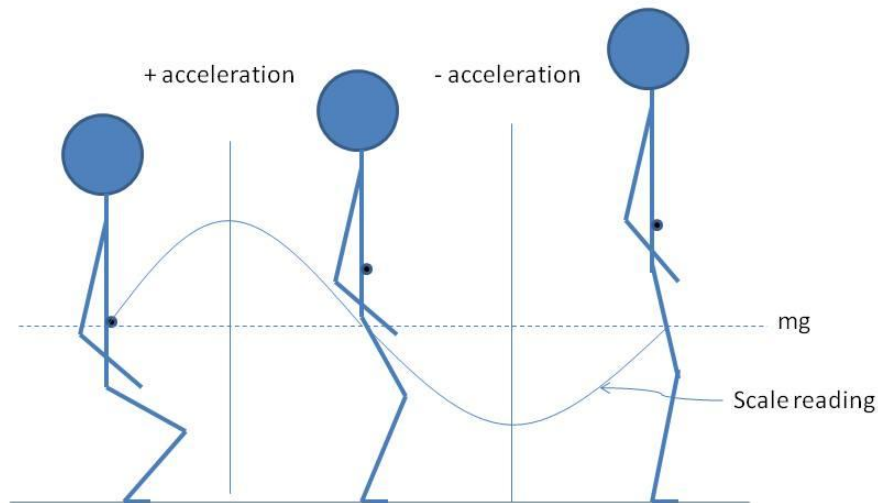

Standing and Falling

To be stable in a standing position the center of mass must be supported by the area on the ground known as the base of support. The mechanics of standing are simple. The center of mass must be located vertically above the base of support with the sum of all forces in all directions equal to zero. The biomechanics of standing is a little different because there are numerous intersegment forces of the arms and legs that all must sum to zero. People can move their arms and hands and shift their hips and move their center of mass but not move their center of mass outside the limits of their support base. The swings of a golf club or a baseball bat are prime examples of these situations. In both situations, when the club moves toward the back swing your center of mass will shift to over the back foot and then as the swing moves forward the center of mass moves toward the front foot. A good example would be to try to swing a bat or club with your feet together to make a smaller support base, keeping your balance is much more difficult.¹¹ Using slow motion video the students can now analysis the shift in the center of mass when swinging a club or bat. They can test how you change your swing by changing your feet spacing

To demonstrate how your center of mass must stay above your feet and how we do not realize how we change the location of our center of mass by shifting parts of our bodies, I will have the student lean over to pick-up a chair by the seat of the chair. All students can

do this because when we lean over we keep our center of mass over our support base by balancing our arms and upper body with our buttocks. Then have students try the same lifting of a chair with their heels against the wall (not allowing them to move their feet). The students cannot even bend over and touch the chair without falling much less lift it off the floor.

Physics of Jumping

The objective of jumping is to lift our weight off the ground or overcome the gravitational force of the earth. To accomplish this we must use our muscles to push on the ground with a greater force than our weight. The height to which we jump is determined by the velocity at which we leave the ground. So the faster we leave the ground the higher we go and the formula to calculate the height from the conservation of energy is $\Delta y = v^2/2g$ (neglecting air resistance). So how do we find the force applied to the ground and our feet to obtain this speed? Using high speed video will slow down the act of jumping my students can measure the distance and the time the force is applied and determine the acceleration and force acting on the floor. The analysis is shown below for a person crouching and jumping. Students can now compare the speed found by how high they jump ($\Delta y = v^2/2g$) to the speed found by the acceleration of the body using their muscles.

Figure 5 The change in center of mass of a person jumping using no arms

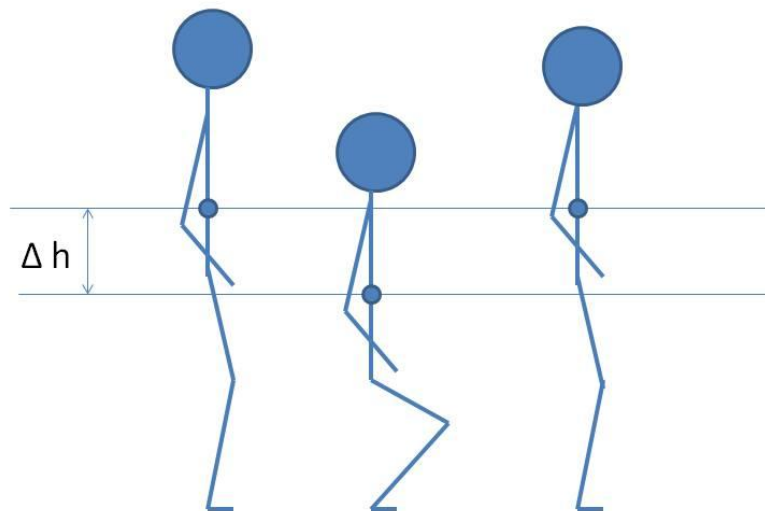

If Figure 5 show a person crouching and accelerating up in preparation for jumping off the ground, the arms are not used to aid in the reaction force of the jump. The net force is found using the following

$$F_{net} = ma = m(v_f - v_i)/\Delta t = \frac{2m\Delta h}{(\Delta t)^2} \text{ assuming } v_i = 0$$

The velocity at which you leave the ground is

$$v_f = 2\Delta h/\Delta t$$

And it can be compared to the velocity based on how high you jump off the ground which is

$$v_o = \sqrt{2g\Delta y}$$

Where g is acceleration due to gravity and Δy is how high you jump.

Students can test how much adding arm movement to the jump can increase the maximum height of their jump. The problem with the additional motion of the arms is the change in the center of mass moving your arm over your head. One of the experiments the students should try is to jump with their arm to their sides. This way the mass of the arms is not contributing to the muscular force of the jump. They will compare the height and speed of the jump with arm movement and without arm movement. In addition students may try to test the affect on height and speed of a jump by bending their arms versus straight arms.

High speed photography can also allow students to analyze jumping at an angle. During projectile motion, the range or horizontal distance is determined by the speed and angle at which the object is launched. If students can measure the horizontal range and launch angle using high speed photography the speed at launch can be determined. Again this speed can be compared to the speed determined by the time and distance the center of mass of the human body moved relative to the ground.

The Physics of Landing

Landing is just the reverse of jumping but instead of giving the body kinetic energy to leave the ground we want to absorb the kinetic energy in work. There are two extremes to the work done by an object. Work is the product of force and displacement or the integral of force and displacement so to reduce the force acting on you in landing the displacement of your center of mass must increase. So when landing by crouching and lowering your center of mass the force acting on your feet is reduced. Moving your arms

from above your head to your sides will increase the displacement of your center of mass and lower your force. Physics analysis of landing with slow motion video is the same as in jumping. If students are going to do any type of analysis of jumping, landing must be involved, what goes up must come down.

Throwing and Catching

Like jumping or landing, throwing and catching is giving the object kinetic energy by doing work and the work is the product of the force and the displacement of the object. Using high speed photography, we can now measure the time and displacement of the object when the muscles are imparting a force on the object. When throwing or catching the bigger the muscle groups involved the greater the force. Also the greater the displacement of not only the arm but also the center of mass the greater the kinetic energy added to the object.

Collision and the Coefficient of Restitution (COR)

When a collision between two objects occurs energy is transferred, the coefficient of restitution is a measurement of the energy that is transferred compared to the energy that is absorbed in the collision. It is calculated as the ratio of the difference of the speed of the object after the collision to the difference in the speed of the objects before the collision.

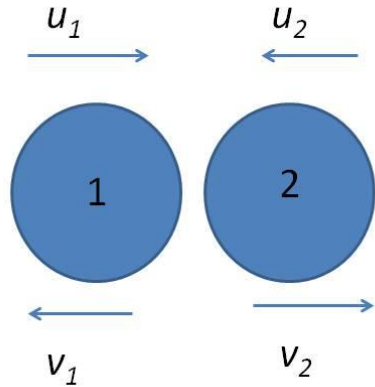

Figure 6 Determining the coefficient of restitution of two objects colliding (COR= e)

Figure 6 shows the collision between two objects and the velocity before, u_1 and u_2 and the velocity after v_1 and v_2 the COR (e) is

$$e = \frac{v_2 - v_1}{u_2 - u_1}$$

A COR (e) of one would mean a perfectly elastic collision where all the energy is transferred. If the first object is not moving like the floor the COR equation becomes

$$e = \frac{v_2}{v_1}$$

If we assume no air resistance then the velocity before the collision with the floor can be determined using the conservation of energy to be $v_1 = \sqrt{2gh_1}$, where g is the acceleration due to gravity and h_1 is the height the object is dropped from. Using the same analysis the COR can also be determined to be the ratio of the square-root of the rebound height h_2 to the dropped height h_1 .¹²

$$e = \frac{\sqrt{h_2}}{\sqrt{h_1}}$$

Student Activities

Students in the International Baccalaureate (IB) program are required to design and conduct an experiment with given basic experimental questions. The students must design a testable question, control variables, collect and analyze data, draw conclusions from the analyzed data and evaluate their conclusion discussing errors and making suggestions for improvement in the experiment. This unit will require IB students to design and experiment to measure motion that cannot be seen or measured without the use of a high speed camera (or slow motion analysis). The high speed camera allows students to measure time to 1/1000 of a second or 1.0 ms which is otherwise impossible to see or measure. It also allows students to stop the motion and determine the distance an object moved. The individual student experiment is open ended; they can perform any reasonable, safe experiment using high speed photography. They will then analyze the motion by measuring the displacement and time for an action and calculating the change in velocity, acceleration and force. The students can do a quantitative analysis of the motion and compare their values to the values based on the height they jump, the speed prior to landing or the COR of a ball on a surface. Students will post the best videos on web. The students will be required to write a laboratory report and make a presentation to the class of their experimental results.

Appendix 1 contains examples of video clips from the first attempt at analyzing motion with the high speed camera. Example 1 shows a student doing a standing broad jump. The three superimposed images are of the jumper using both arms, swinging only once then using the right arm swing once, then the left arm swinging once. It is clear from the images that swinging both arms increases the distance you can jump by increasing the speed at which the jumper leaves the ground. These videos were taken at 240 frames per second. The second set of images is from a video of a water balloon being broken by a pin. The video was filmed at 480 frames per second. The final video is of a ball bouncing off the floor recorded at 1000 frames per second. The ball in this video was in contact with the floor for only 5 frames or 5/1000 of a second. The camera used was a Casio Exilim ZR100. If you do not have the high speed camera the same analysis can be done using high speed or slow motion videos found on the web.

¹ Griffiths, Iwan W. *Principles of biomechanics & motion analysis*. (Philadelphia: Lippincott Williams & Wilkins, 2006), 85.

² Chapman, Arthur E. *Biomechanical analysis of fundamental human movements*. (Champaign, IL: Human Kinetics, 2008), 37.

³ Chapman, 38.

⁴ Hill, A.V. "The Heat of Shortening and the Dynamic Constants of Muscle." *Proceedings of the Royal Society of Biological Sciences* 126, no. 843 (1938): 136-195.

⁵ Phillips, C.A., D.W. Repperger, A.T. Neidhard-Doll, and D.B. Reynolds. "Biomimetic model of skeletal muscle." *Computers in Biology and Medicine* 34 (2004): 307-322.

⁶ Phillips, 308.

⁷ Chapman, 39.

⁸ Chapman, 40

⁹ Chapman, 42

¹⁰ Chapman, 46

¹¹ Chapman, 58

¹² Hall, Susan J. *Basic biomechanics*. (3rd ed. Boston: WCB/McGraw-Hill, 1999) 401.

Works Cited

Chapman, Arthur E. *Biomechanical analysis of fundamental human movements*. Champaign, IL: Human Kinetics, 2008.

Griffiths, Iwan W. *Principles of biomechanics & motion analysis*. Philadelphia: Lippincott Williams & Wilkins, 2006.

Hall, Susan J. *Basic biomechanics*. 3rd ed. Boston: WCB/McGraw-Hill, 1999.

Hill, A.V. "The Heat of Shortening and the Dynamic Constants of Muscle." *Proceedings of the Royal Society of Biological Sciences* 126, no. 843 (1938): 136-195. <http://rspb.royalsocietypublishing.org/content/126/843/136.citation#related-urls> (accessed November 21, 2011).

Phillips, C.A., D.W. Repperger, A.T. Neidhard-Doll, and D.B. Reynolds. "Biomimetic model of skeletal muscle." *Computers in Biology and Medicine* 34 (2004): 307-322. <http://digitalcommons.unl.edu/usafresearch/29> (accessed November 21, 2011).

Resources

Adair, Robert Kemp. *The physics of baseball*. 2nd ed. New York: HarperPerennial, 1994. Excellent reference with good graphics

Chapman, Arthur E. *Biomechanical analysis of fundamental human movements*. Champaign, IL: Human Kinetics, 2008.

Relates biomechanics to human movement and describes the physics of muscular force.

Griffiths, Iwan W. *Principles of biomechanics & motion analysis*. Philadelphia: Lippincott Williams & Wilkins, 2006.

Written for students studying human movement using examples with real data that will challenge and build problem solving skills.

Hall, Susan J. *Basic biomechanics*. 3rd ed. Boston: WCB/McGraw-Hill, 1999.
Introduction to biomechanics very good basic text.

Hamill, Joseph, and Kathleen Knutzen. *Biomechanical basis of human movement*. 2nd ed. Philadelphia: Lippincott Williams & Wilkins, 2003.

It integrates basic functional anatomy, physics, calculus, and physiology for the study of human movement with real-life examples.

Hill, A.V. "The Heat of Shortening and the Dynamic Constants of Muscle." *Proceedings of the Royal Society of Biological Sciences* 126, no. 843 (1938): 136-195.

<http://rspb.royalsocietypublishing.org/content/126/843/136.citation#related-urls> (accessed November 21, 2011).

The original paper from 1938 that describes the original experiment to measure muscular force. very long and detailed.

Holmes, Jeffery. "Teaching from classic papers: Hill's model of muscle contraction."

Advan in Physiol Edu 30:67-72, 30, no. 2 (2006): 67-72.

<http://advan.physiology.org/content/30/2/67.abstract> (accessed November 19, 2011).

Hill's model of muscle contraction explained with updated graphs.

Phillips, C.A., D.W. Repperger, A.T. Neidhard-Doll, and D.B. Reynolds. "Biomimetic model of skeletal muscle." *Computers in Biology and Medicine* 34 (2004): 307-322. <http://digitalcommons.unl.edu/usafresearch/29> (accessed November 21, 2011).

The best explanation of Hill's model of muscle contraction.

Walker, James S.. *Physics*. 2nd ed. Upper Saddle River, NJ: Pearson/Prentice Hall, 2004.
My classroom textbook a good physics reference.